

## EFFECTIVENESS OF THE ACTIVE PNEUMATIC SUSPENSION OF THE OPERATOR'S SEAT OF THE MOBILE MACHINE IN DEPEND OF THE VIBRATION REDUCTION STRATEGIES

Stefan Chwastek, Janusz Pobędza

Cracow University of Technology  
Faculty of Mechanical Engineering  
Jana Pawła II Av. 37, 31-864 Krakow, Poland  
tel.: +48 12 3743360, fax: +48 12 3743409, +48 12 3743341  
e-mail: stefan.chwastek@mech.pk.edu.pl  
janusz.pobedza@mech.pk.edu.pl

### Abstract

Low speeds of heavy mobile machines combined with large inertia result in the excitation of low frequency vibrations. Dissipation of vibration energy in the case of unsprung machines is performed only through tires, which slightly reduces the intensity of vibrations. Effective reduction of vibrations of mobile machines is possible only with active or semi-active methods. In unsprung mobile machines, on the way of propagation of vibrations between the source of vibrations and the protected object (machine operator), are vibroisolation systems located. These are most often controlled seat suspensions. In the case of the active suspensions, it is necessary to provide external energy, e.g. in the form of compressed air. The compressed air has the advantage that it is generally available in working machines as the working fluid and has its environmentally friendly properties (leaks do not contaminate the environment). This article is the result of the continuation of work on active methods of vibro-activity lowering in mobile machines, which resulted in, among others, elaboration of simulation model of the active operator's seat suspension with controlled pneumatic actuator and its experimental identification. In particular, it was verifying the effectiveness of the adopted solution made the identification the friction model and thermodynamic phenomena in the controlled pneumatic cylinder. The aim of this work is parametric optimization of the suspension system and searching for the optimal control strategy. Experimental tests were carried out under conditions of harmonic excitations, coming from the electromechanical vibration exciter with controllable pitch and frequency. Data acquisition system and control circuit of the proportional directional control valve, supplying compressed air to the actuator were implemented using MATLAB-Simulink Real-Time software.

**Keywords:** unsprung mobile machines, active vibration reduction, controlled suspension seats, pneumatic actuator

### 1. Introduction

Mobile machines during the ride induce intensive low-frequency vibrations, which cannot be effectively reduced by passive methods. Energy dissipation in wheel tires reduces the vibration intensity in a minor degree only. Unsprung mobile machines are usually equipped with system of vibration isolation, which is located on the way of vibration propagation, between the vibration source (cab floor) and the protected object (the operator of the machine). Active reduction systems require an external source of energy. The compressed air has the advantage that it is generally available in heavy machines. Fig 1a shows the kinematic system of the seat suspension but Fig. 1b replacement model of the active seat suspension model of an active seat suspension in which a controlled pneumatic cylinder exerts the force  $F(s)$  upon the seat platform.

The absolute movement of the seat with the operator in the condition of the floor vibration –  $z(t)$  is expressed by the equation:

$$q(t) = y[s(t)] + z(t). \quad (1)$$

The relative seat movement –  $y(s)$  is determined by the controllable length of the pneumatic

cylinder –  $s$ . In this case  $y(s) = s$  (omission of the kinematic system structure Fig. 1a. Taking into account friction in sliding pairs, vertical vibration of the operator sitting on the seat mounted is governed by the equation:

$$m \frac{d^2 q}{dt^2} = F(s) - T_{1,2} \cdot \text{sign} \left( \frac{ds}{dt} \right) - G. \quad (2)$$

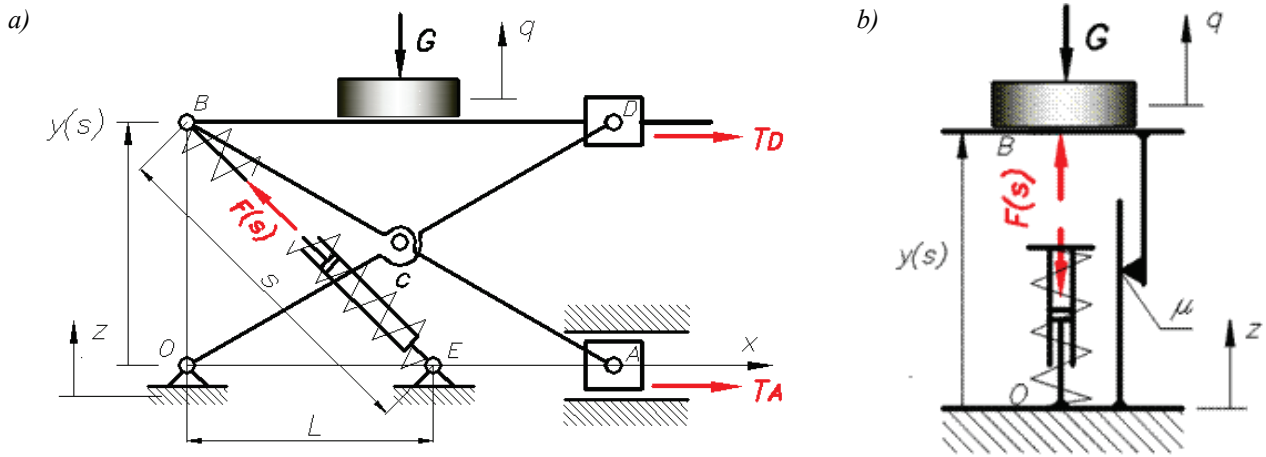

Fig. 1. Kinematic system of the seat suspension (a). Replacement model of the active seat suspension (b)

The total force  $F(s)$  determining the seat mount mechanism's motion involves the active component due to air pressure, friction in the cylinder sealing, spring response and viscous friction:

$$F(s) = p_1 A_1 - p_2 A_2 + F_T - c(s - s_{\max}) - k \frac{ds}{dt}. \quad (3)$$

Active seat suspension systems incorporate relief springs to reduce the energy expenditure. The complexity of the physical and mathematical model was written in articles [1, 2] based on [3-5].

The process of object identification involves determining of the parameters of a mathematical model describing the accepted model of the physical object. The complexity of the physical and mathematical model should be adapted to the purpose of research.

In most cases, vibration reduction is effected through the use of controlled seat suspensions.

### 3. Comparison of a regulated single-acting and double-acting pneumatic actuator

As regards the sensitivity to vibration in the vertical direction, humans most rapidly respond to vibration in the frequency range 4-8 Hz. In consideration of the ride comfort, of particular importance is minimizing the acceleration of the driver's torso vibration. In the [1] presented the simulation of active system based on *PID* regulator with single-acting pneumatic actuator. Its effectiveness is nearly twice as high as that of the passive system. The efficiency of the seat suspension active system in the frequency range [0-10] Hz was evaluated basing on the transmissibility function for vibration acceleration  $-\alpha(f)$ . Transmissibility function for the active system (*PID* regulator in the on state) is designated by  $-\alpha_{PID}$  and graphed with a thick line. For comparison, the transmissibility function for the passive system (*PID* regulator in the off state) is designated by  $-\alpha$  and graphed with a thin line.

The active system is most effective in the neighbourhood of resonance frequency. Its effectiveness is nearly twice as high as that of the passive system. In the super-resonance range (in excess of 6 Hz); vibration isolation performance of the active and passive systems is nearly identical. The active system behaves like a real vibration isolator ( $\alpha_{PID} < 1$ ) for frequencies

$f > 2.5$  Hz, the passive system – for  $f > 3.5$  Hz. The results of simulation tests were verified experimentally in laboratory stand with physical model of the active suspension of the operator's seat. Schematic diagram of the pneumatic system of the active seat suspension is shown in Fig. 3.

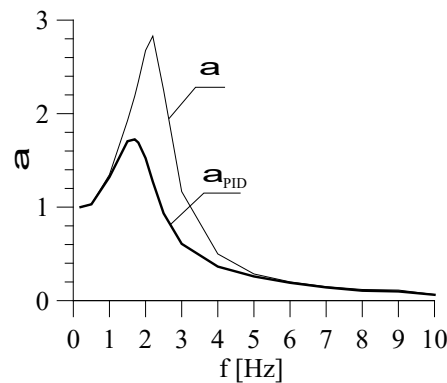

*Fig. 2. Transmissibility function of a regulated single-acting pneumatic actuator*

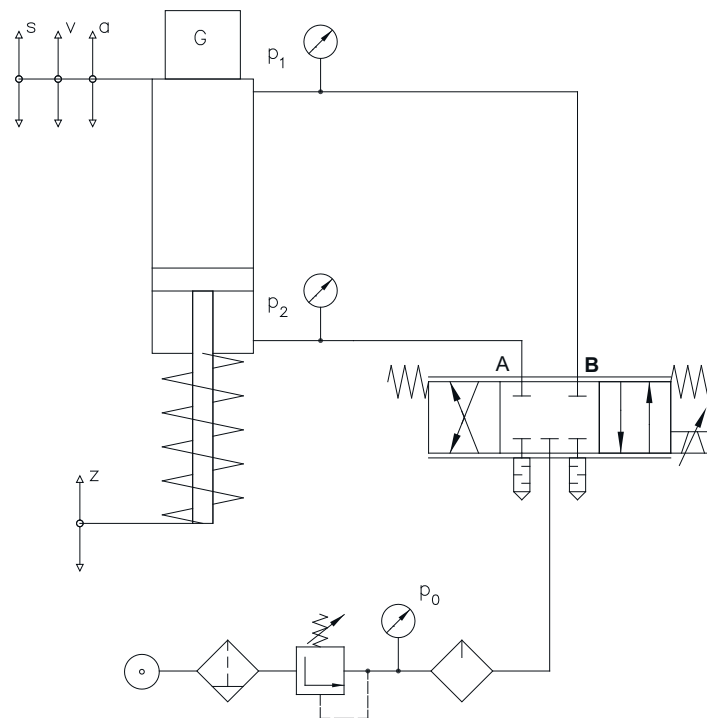

*Fig. 3. Schematic diagram of control of the pneumatic cylinder*

Flow control is effected through throttling of the mass flow rate of air supplied and released from the cylinder. View of the laboratory stand with physical model of the active suspension of the operator's seat is presented in Fig. 4 and 5. Test stand includes both mechanical and pneumatic system.

Data acquisition system and control circuit of the proportional directional control valve, supplying compressed air to the actuator were implemented using MATLAB-Simulink Real-Time software (Fig. 6).

The stand allows system testing at different frequency and amplitude of excitation, at different values of supply pressure  $p_0$ . The use of MATLAB-Simulink Real-Time software allowed for flexible shaping of the structure and coefficients of the controller. In the tests, the system of active vibration reduction of the driver's seat with the *PID* controller was tested, with the target function: minimization of vibration accelerations and minimization of the amplitude of the seat

displacement. Fig. 7 presents transients of parameters characterizing the system operation with the controller turned on and off. Constant voltage value  $U$  means operation with the controller switched off. By adjusting the pressure  $p_1$  and  $p_2$ , the controller reduces the vibrations of the seat.

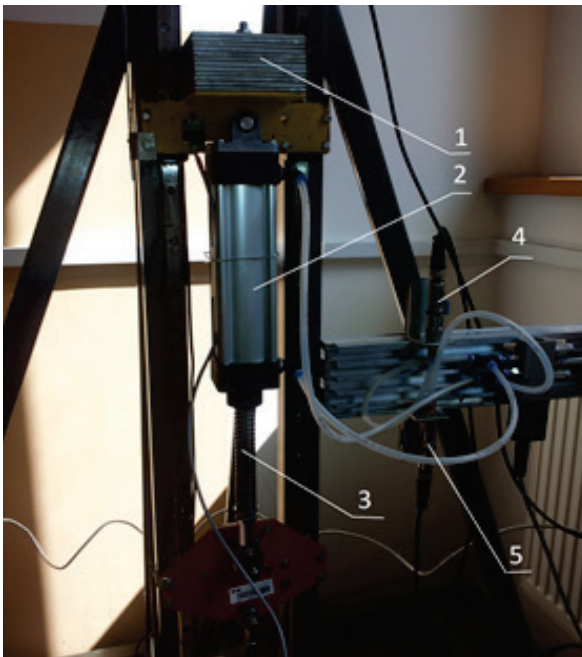

Fig. 4. General view of the test stand: 1 – weight  $G$ , 2 – pneumatic cylinder, 3 – spring, 4, 5 – pressure transducer

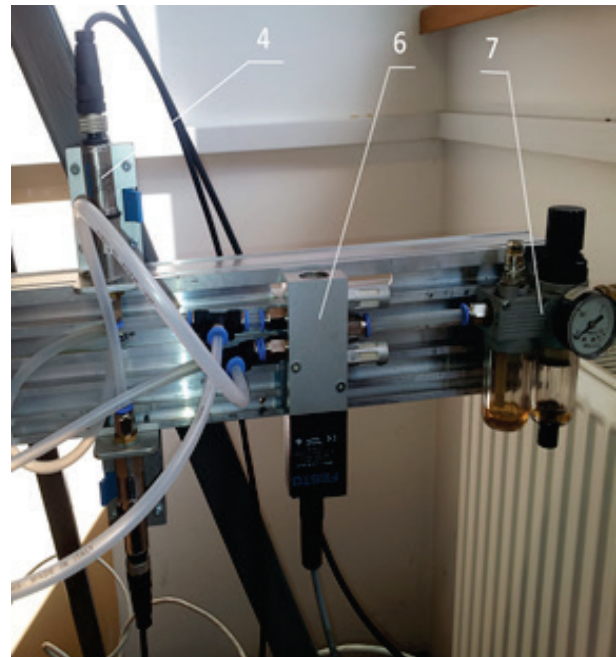

Fig. 5. View of the pneumatic control unit, pneumatic cylinder: 4 – pressure transducer, 6 – proportional directional control valve, 7 – air conditioner

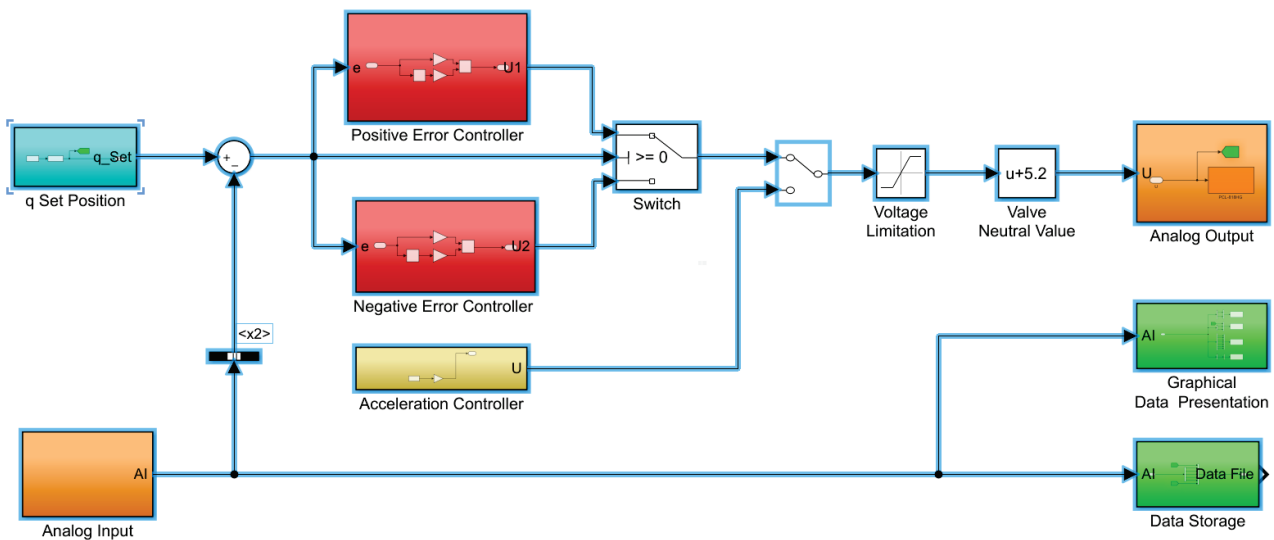

Fig. 6. Diagram of the control and data acquisition system implemented in MATLAB-Simulink Real-Time software

Based on experimental research, a comparative frequency response, in the range of 0-6 Hz was developed, representing the function of the transition between the accelerations of seat vibrations with respect to the excitation acting on the seat base. This characteristic is shown in Fig. 8, where the thin line represents the passive system and the thick line is the active system with the  $PID$  controller. Experimental studies of the active system showed a significant reduction of vibrations in the range up to 2.5 Hz. In resonance at the frequency  $f = 2$  Hz, the degree of vibration reduction  $\alpha/\alpha_{PID} = 3$ . Observation of recorded waveforms of some physical variables of the active system showed the limitations of the pneumatic sub-system, related to insufficient airflow.

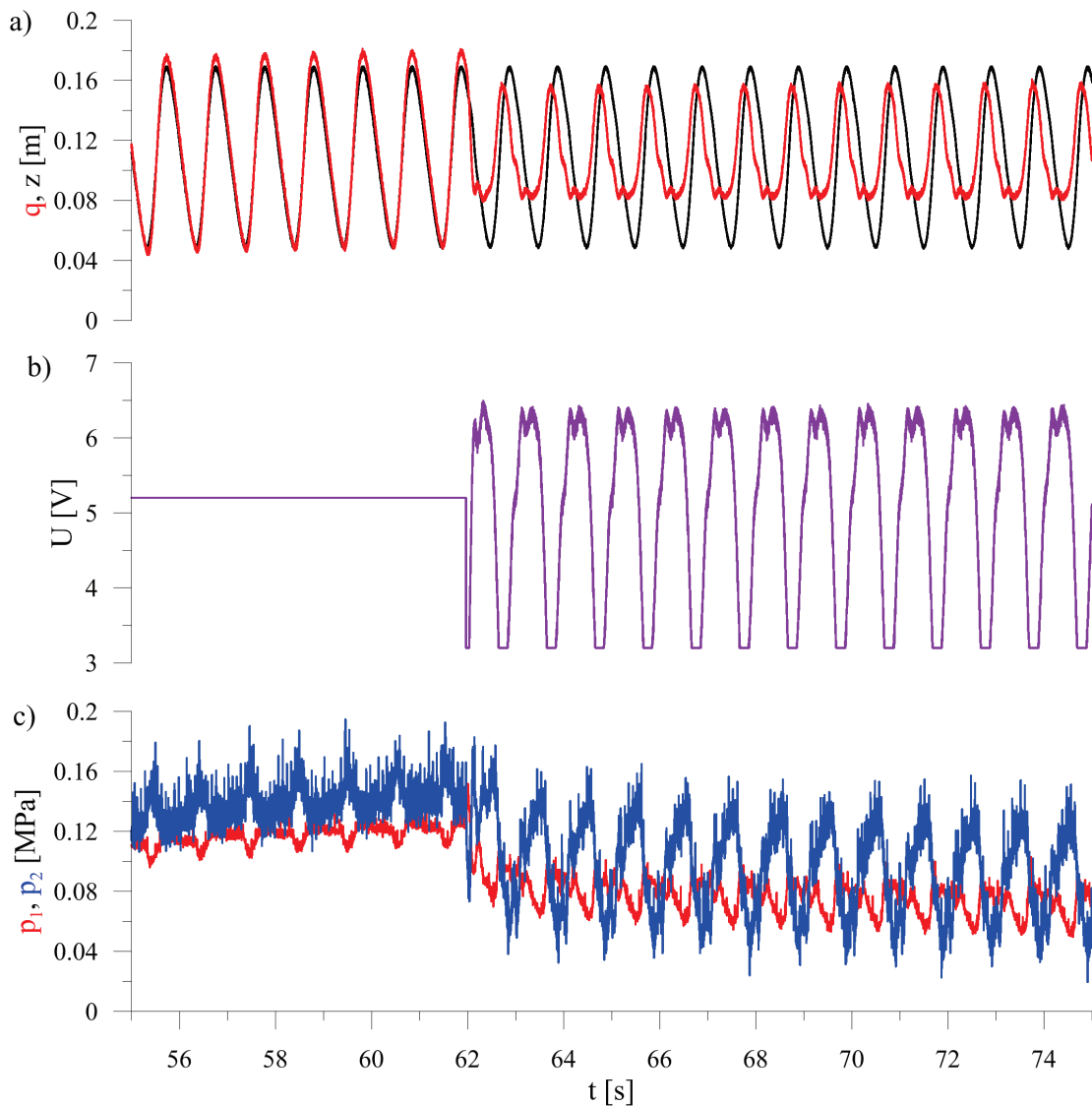

Fig. 7. Waveforms of: a) the vertical vibrations operator's seat versus base vibrations, b) controlling the mass flow rate of air supplying the actuator using the voltage signal from a servo-valve, c) pressure  $p_1, p_2$  in cylinder chambers

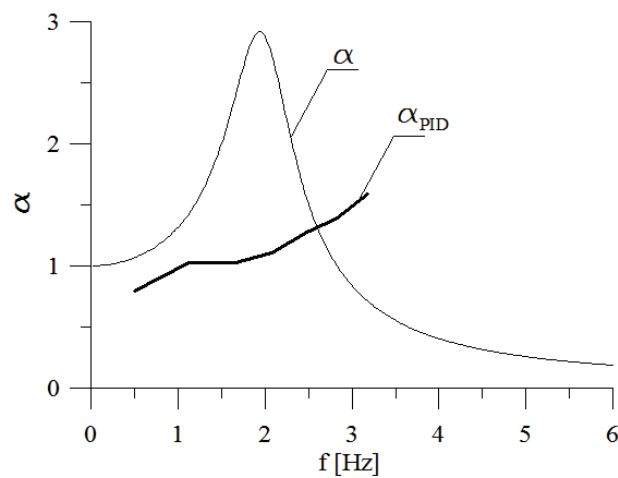

Fig. 8. Frequency response of passive and active systems

The result is an insufficient rate of pressure changes in the pneumatic cylinder chambers. This phenomenon intensifies with the increase of excitation frequency.

#### 4. Conclusions

The built-up test stand of the active suspension system of the mobile machine operator's seat allowed the identification of the values characterizing the suspension operation and the determination of the vibration reduction coefficient as a function of frequency. Significant reduction of vibrations, in the range around resonance was obtained, which confirms the validity of using active pneumatic systems. It is possible to increase the efficiency of the system, both in terms of the reduction vibrations degree and the bandwidth of the frequency band. However, it requires modification of the pneumatic system consisting in increasing the throughput and speed of the proportional directional control valve reaction.

#### References

- [1] Chwastek, S., *Active vibration reduction operator's seat with the use of controlled single-acting pneumatic actuator*, Journal of KONES Powertrain and Transport, Vol. 22, No. 3, pp. 13-20, 2015.
- [2] Chwastek, S., Koziół, P., *Semiactive reduction of vibration operator's seat with the use of controlled magnetorheological damper*. Journal of KONES Powertrain and Transport, Vol. 22, No. 4, pp. 59-66, 2015.
- [3] Flis, K., Pobędza, J., *Simulation of pneumatic motor used in pneumobile*, Journal of KONES Powertrain and Transport, Vol. 21, No. 3, 2014.
- [4] Kamiński, Z., *Modelowanie nieliniowości i nieciągłości w pneumatycznych siłownikach tłokowych*, Hydraulika i Pneumatyka, Nr 2, 2006.
- [5] Kościelny, W., *Hamowanie siłowników pneumatycznych*, Hydraulika i Pneumatyka, Nr 4, 2004.

*Manuscript received 15 May 2018; approved for printing 03 September 2018*