

# THE FREQUENCY CONVERTER CONTROL METHOD IN POSITIONING AND STABILISATION OF A PLATFORM SUSPENDED ON ROPES IN CONDITIONS OF A TIME-VARIANT CENTRE OF GRAVITY

Stefan Chwastek

Krakow University of Technology  
Institute of Machine Design  
Jana Pawła II Av. 37, 31-864 Kraków, Poland  
tel.: +48 12 3743360, fax: +48 12 3743409  
e-mail: chwastek@mech.pk.edu.pl

## Abstract

*When handling materials in space it is required that the materials to be hoisted should be stabilised and their position precisely controlled. Attempts are made to minimise the dynamic loading during the start-up and braking phase and to reduce vibration of the material being handled, at the same time ensuring the minimal time of operation. When the admissible value of positioning and levelling errors are very small, some effective methods of drive control are required. This study investigates an asymmetrically loaded platform suspended on ropes and people moving with respect to it during the hoisting phase. The positioning and levelling errors are minimised by controlling voltage fluctuations of the current supplying asynchronous induction motors. The proposed solution uses an optimal LQR controller. Both free and forced vibrations of the platform are low-frequency vibrations, so the scalar method of controlling the output voltages are recommendable, where feedback loops in the electro-magnetic part of the system are neglected. The losses and time delays associated with modulation of the velocity characteristics of the induction motor being omitted, the optimal control strategy of frequency control is developed to effectively handle the control plant. This study has demonstrated the possibility of limited control of an object where the number of DOFs is larger than that of independent drives.*

**Keywords:** *optimal controller, automatic control system, simulation, asynchronous induction motor, hoisting winch*

## 1. Introduction

Asymmetry of the platform's loading is responsible for different tensioning of supporting ropes and, consequently, for differences in the loading of driving motors. If this asymmetry becomes a constant feature, working points will be revealed on the velocity characteristics of driving motors and, depending on the static loading of each motor, the average rpm will be established. As a result, ropes are wound on the drum at different rate, causing the platform to be inclined in the direction of the eccentric. When the platform loses its horizontal position, people standing upon it or beneath are exposed to danger from falling objects or spilling liquids.

When the persons in the platform begin to move with respect to it, that gives rise to the variable loading components acting on each rope. The driving motors deliver the torque to adapt to the applied loading moment and the average rpm will not be established. Dynamic processes associated with the platform motion will become non-stationary.

As it was reported in [3], conventional suspended platform systems emulating the behaviour of a physical model discussed in [1-3] are most sensitive to excitations acting in the horizontal direction. In order to effectively control horizontal and angular motions of the platform (such as those caused by moving people) it is required that the impacts of horizontal components of the rope loading force be duly enhanced. A potential solution here is to control the distance between the winder drums' axes. The purpose of this study is to develop an automatic control system to stabilise the platform in the horizontal position whilst in service, taking into account potential

disturbances due to people moving. The proposed solution uses an optimal LQR controller to control the current supplying the stator coils in each of the induction motors.

## 2. Physical model of a platform suspended on ropes

The physical model of the system comprising a platform supported on two hoisting winders is shown in Fig. 1. The number of DOFs of the system assumed to be planar equals 5, the flexibility of the driving systems being neglected.

Particular DOFs are represented by the elements of the vector of generalized coordinates  $\mathbf{q}(t) = [x(t), y(t), \varphi(t), \varphi_1(t), \varphi_2(t)]^T$ . The planar motion of the platform as a rigid solid is described by the variables:  $x(t), y(t), \varphi(t)$ . Coordinates  $\varphi_1(t), \varphi_2(t)$  represent angular displacements of the drums. Inertia moments of all rotating elements are reduced to the winder drums and designated as  $J_{s1}$  and  $J_{s2}$ . The winders deliver the torque designated as  $M_1, M_2$ .

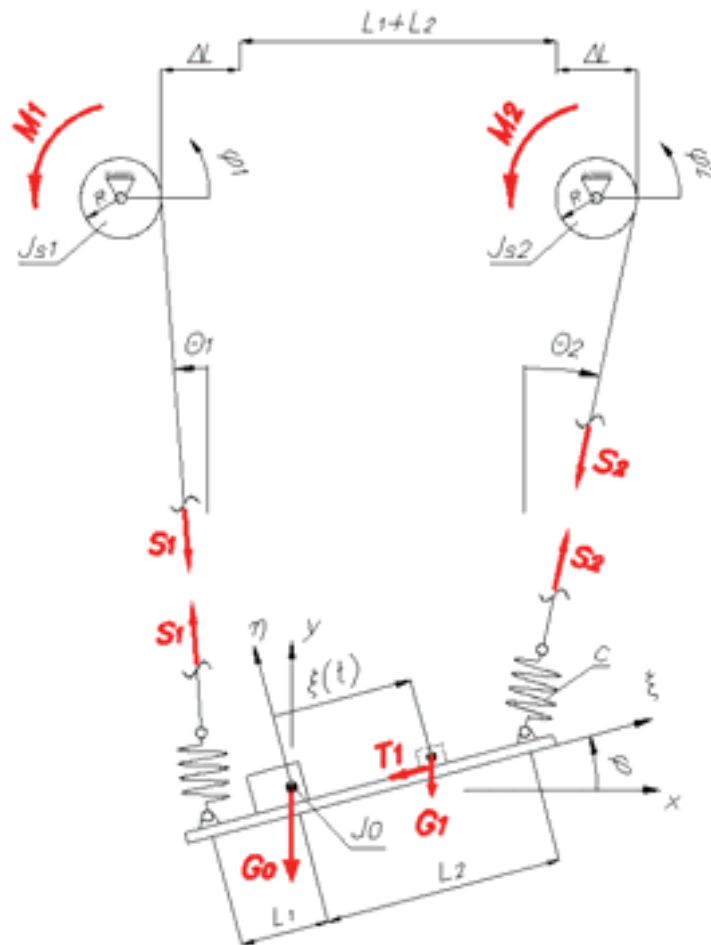

Fig. 1. Physical model of a platform suspended on a double-winch

Rope flexibility is proportional to its effective length –  $l$ . In accordance with [7], the averaged value of the Young modulus is assumed to be  $E = 125$  GPa for ropes with a non-metallic core, and the modulus of elasticity of the rope is obtained from the formula:

$$c(l) = n \frac{EA}{l}, \quad (1)$$

where:

- $A$  – effective cross-section area of the rope,
- $n$  – multiplicity of the pulley block.

Damping in the ropes is assumed to be proportional to the modulus of elasticity through the dimensionless damping factor  $\zeta_0 = 0.015$ . The payload is assumed to be immobile with respect to the platform and hence its weight  $G_0$  can be expressed as the sum of its own weight and that of the platform. The distance between the resultant c.o.g. (centre of gravity) of the weight of the payload and the platform and the rope attachment points are given as  $L_1, L_2$ .

The variable  $\xi$  denotes the displacement of a human with the weight  $G_1$  with respect to the platform. The angles  $\Theta_1$  and  $\Theta_2$  representing the ropes' position out of plumb can be expressed by relevant trigonometric functions expressed in generalised coordinates.

$$\sin(\Theta_1) = \frac{x - L_1 \sin(\varphi)}{l_1}, \quad (2)$$

$$\sin(\Theta_2) = \frac{x - L_2 \sin(\varphi) - (L_1 + L_2 + \Delta L)}{l_2}. \quad (3)$$

The elastic extension of the rope  $-\Delta l_i$  is negligibly small in relation to the rope length  $-l_i$  and does not affect the angles  $\Theta_1$  and  $\Theta_2$ .

Assuming that a person moving with respect to the platform will remain in contact with the floor, the equations of motion of a suspended platform are given as:

$$\left. \begin{aligned} (m_0 + m_1) \frac{d^2 x}{dt^2} + \frac{d^2 \mu_2}{dt^2} &= S_1 \sin(\Theta_1) + S_2 \sin(\Theta_2), \\ (m_0 + m_1) \frac{d^2 y}{dt^2} + \frac{d^2 \mu_1}{dt^2} &= S_1 \cos(\Theta_1) + S_2 \cos(\Theta_2) - G_0 - G_1, \\ -\mu_2 \frac{d^2 x}{dt^2} + \mu_1 \frac{d^2 y}{dt^2} + J \frac{d^2 \varphi}{dt^2} &= S_2 L_2 \cos(\varphi + \Theta_2) - S_1 L_1 \cos(\varphi + \Theta_1) - G_1 \xi \cos(\varphi) - 2m_1 \frac{d\varphi}{dt} \xi \frac{d\xi}{dt}, \\ J_{s1} \frac{d^2 \varphi_1}{dt^2} &= M_1 - S_1 r, \\ J_{s2} \frac{d^2 \varphi_2}{dt^2} &= M_2 - S_2 r, \end{aligned} \right\} (4)$$

where:

$$m_i = \frac{G_i}{g}, \quad i = 0, 1, \quad (5)$$

$$J = J_0 + m_1 \xi^2, \quad (6)$$

$$\mu_1 = m_1 \xi \sin(\varphi), \quad (7)$$

$$\mu_2 = m_1 \xi \cos(\varphi), \quad (8)$$

### 3. Synthesis of the optimal control system

In the context of the adopted model of applied excitations, equations of motion of the platform (4) can be written in the space of the state in the matrix format:

$$\frac{d}{dt} \mathbf{z} = \mathbf{A} \mathbf{z} + \mathbf{B} \mathbf{u} + \mathbf{R} \mathbf{w}, \quad (9)$$

where:

$\mathbf{A}$  – matrix of state,

**B** – control matrix,  
**R** – matrix of applied excitations,  
**w** – vector of applied excitations,  
**z** – vector of state,  
**u** – control vector.

And:

$$\mathbf{z} = \begin{bmatrix} \mathbf{q} \\ \frac{d\mathbf{q}}{dt} \end{bmatrix} = \left[ x, y, \varphi, \varphi_1, \varphi_2, \frac{dx}{dt}, \frac{dy}{dt}, \frac{d\varphi}{dt}, \frac{d\varphi_1}{dt}, \frac{d\varphi_2}{dt} \right]^T. \quad (10)$$

The automatic system to control the platform movements is shown as a block diagram in Fig. 2.

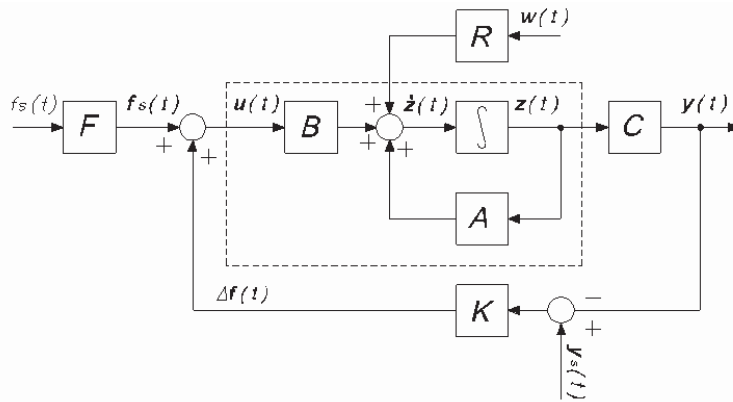

Fig. 2. Block diagram of an automatic control system with the input  $f_s(t)$

A two-element reference input vector –  $\mathbf{f}_s(t)$  of the control system involves the signals of programmed frequency modulation of supply voltage to asynchronous motors –  $f_s(t)$ . The trajectory of motion can be determined accordingly.

The function of frequency modulation for the platform being elevated to the height 25 m within the time  $T = 35$  s is shown in Fig. 3, taking into account a two-second start-up and braking phase during which the hoisting speed varies sinusoidally and the transition to the steady state is assumed to be smooth. Besides, a two-second delay in the system’s operation is assumed.

In the case considered here all variables of state are measurable, either directly or indirectly, which implicates that the adopted measurement matrix  $\mathbf{C} = \mathbf{I}$ , allowing for the synthesis of the optimal LQR controller.

The controller provides the correction of the frequency modulation of supply voltage to the reference input through the feedback loop in the form of signals  $\Delta f_1$  and  $\Delta f_2$ .

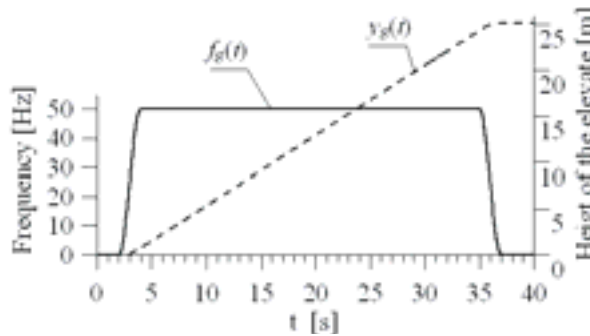

Fig. 3. Programmed frequency modulation of supply voltage  $f_s(t)$  for the specified vertical displacement of the platform  $y_s(t)$

The feedback signal from the coordinate of the vector of state is generated in accordance with [6]:

$$\mathbf{u}(t) = \mathbf{K} \cdot [\mathbf{z}_s(t) - \mathbf{z}(t)] + \mathbf{F} \cdot \mathbf{f}_s(t), \quad (10)$$

where:

$\mathbf{K}$  – the desired feedback matrix,

$\mathbf{F}$  – forecast matrix.

Controlling the rpm of the induction motors involves the frequency modulation of voltage fluctuations. The scalar method is applied here, based on a frequency converter to adjust the stator voltage  $U$ , proportional to frequency  $f$ , to stabilise the magnetic flux [9].

The control strategy is based on steady-state mechanical characteristics of the motor, reduced to the drum in the winder.

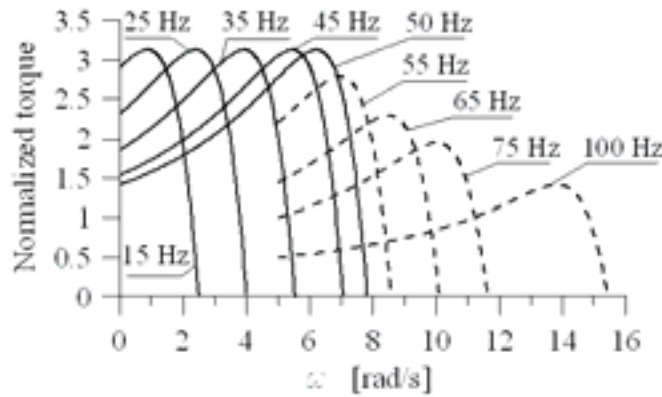

Fig. 4. Mechanical characteristics of an asynchronous induction motor controlled by adjusting the frequency of voltage supplying the stator winding, reduced to the drums in the winder

The control quality criterion, based on the sum of squared deviations of state variables and control variables from the values resulting from the predetermined trajectory to be achieved within the specified time period  $T$ , is expressed as a functional [5, 6]:

$$J = \lim_{T \rightarrow \infty} \int_0^T [\mathbf{z}^T \mathbf{Q} \mathbf{z} + \mathbf{u}^T \mathbf{P} \mathbf{u}] dt, \quad (11)$$

where:

$\mathbf{Q}$  – weight matrix for the coordinates of state,

$\mathbf{P}$  – weight matrix for control.

To ensure the optimal control, represented by the minimum of the functional (11), it is required that the matrix  $\mathbf{X}_{\text{opt}}$  should be determined, being the solution of the Riccati's differential equation [6]:

$$\dot{\mathbf{X}}_{\text{opt}} + \mathbf{X}_{\text{opt}} \cdot \mathbf{A} + \mathbf{A}^T \cdot \mathbf{X}_{\text{opt}} - \mathbf{X}_{\text{opt}} \cdot \mathbf{B} \cdot \mathbf{P}^{-1} \cdot \mathbf{B}^T \cdot \mathbf{X}_{\text{opt}} + \mathbf{Q} = \mathbf{0}, \quad (12)$$

The optimal feedback matrix  $\mathbf{K}$  is written as:

$$\mathbf{K}(t) = -\mathbf{P}^{-1} \cdot \mathbf{B}(t)^T \cdot \mathbf{X}_{\text{opt}}(t). \quad (13)$$

#### 4. Position control and stabilization of the platform

The simulation procedure is supported by Matlab-Simulink®. A platform 4 m in length is considered, loaded with the total weight  $G_0 = 6000$  N applied at the distance  $L_1 = 1$  m from its left edge, the weight  $G_1$  being 1000 N.

The model of a person's movement with respect to the platform is shown in Fig. 5, in the form of plots of displacement derivatives.

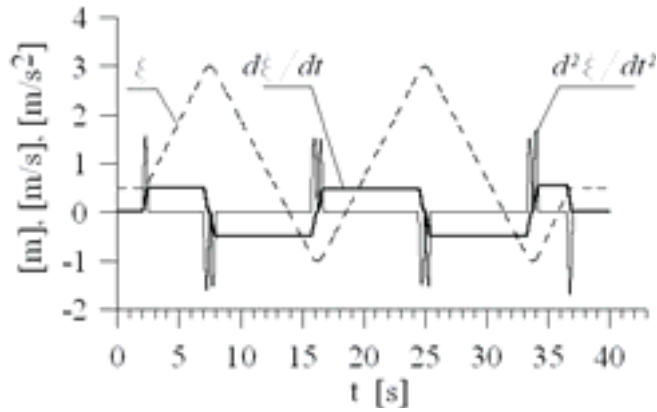

Fig. 5. Derivatives of a person's displacement with respect to the platform

The controller's performance is evaluated basing on the amplitudes of the platform's horizontal vibration and positioning and levelling errors, shown in Fig. 6-8, respectively.

Red broken lines indexed with  $-s$  represent the static equilibrium conditions. Blue lines with letters containing the index  $-c$  represent the working conditions when the automatic control system is on. Black lines represent the off-state of the automatic control system.

Input excitations give rise to large-amplitude vibration of the platform in the horizontal direction. In accordance with the adopted mathematical model, these undamped vibrations can be handled effectively by the automatic control system.

It is readily apparent (see Fig. 6) that horizontal vibrations of the platform, both free and forced, can be effectively controlled.

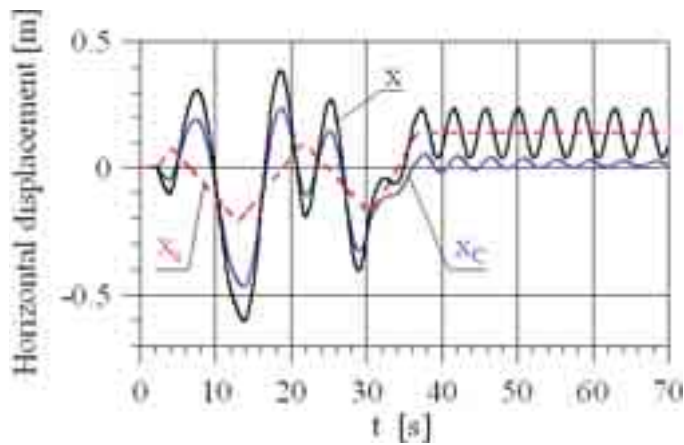

Fig. 6. Horizontal displacement

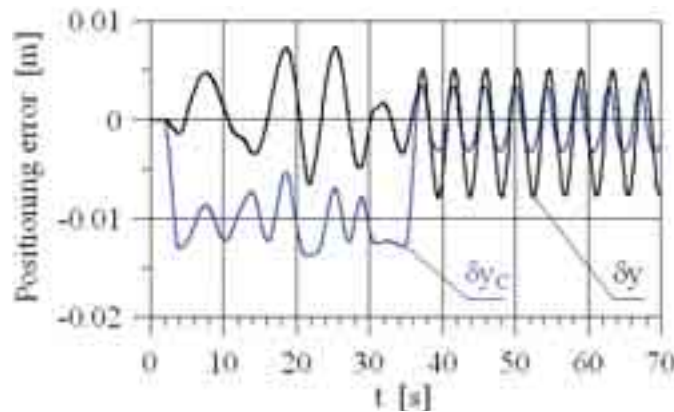

Fig 7. Positioning error

In a minor degree only is the positioning error associated with disturbances caused by a person moving with respect to the platform.

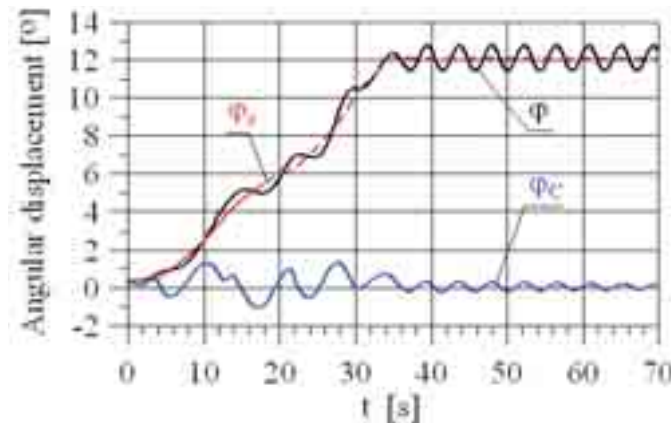

Fig. 8. Leveling error

Towards the end of the hoisting phase the platform tilting exceeds  $12^\circ$ , involving angular vibrations with the amplitudes in excess  $1^\circ$ . When the automatic control system is switched on, the platform's tilt is nearly wholly eliminated. Amplitudes of angular vibration in the early phase of the applied input do not exceed  $1.5^\circ$  and are shortly reduced to levels deemed negligible in the light of the safety features.

One has to bear in mind that the platform's vibrations are mostly low-frequency vibrations. The fact that the controllability and observability conditions [5, 6], can be satisfied proves the adequacy of the control strategy through frequency modulation of the supply voltage.

The controller's settings are sought therefore, such that horizontal and angular vibrations could be effectively handled.

The plots of control errors are obtained for the frequency modulation of supply voltage, shown in Fig. 9. The developed control strategy through frequency modulation of the supply voltage to induction motors in the winder utilises the scalar method of controlling the waveforms of output voltage signals.

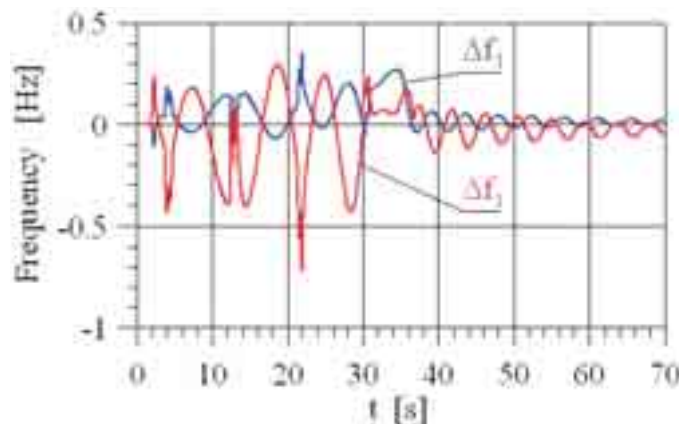

Fig. 9. Frequency correction

The variability range of correcting signals proves that the proposed control method is physically implementable.

## 5. Conclusion

Risks associated with personnel moving with respect to the platform are very real and can never be wholly eliminated. Application of a LQR controller in the hoisting systems helps in reducing the positioning and control errors.

As it is demonstrated, horizontal and angular vibrations can be effectively reduced provided that the impacts of horizontal components of the tensioning forces acting in ropes should be enhanced, for instance by controlling the spacing –  $\Delta L$  between the drums' axes in the winders. Simulation results are obtained for the distance between the drums axes  $\Delta L = 1$  m.

Both free and forced vibrations of the platform are low-frequency vibrations, so the scalar method of controlling the output voltages are recommendable, where feedback loops in the electro-magnetic part of the system are neglected [9].

The losses and time delays associated with modulation of the velocity characteristics of the induction motor being omitted, the optimal control strategy of frequency control is developed to effectively handle the control plant.

One has to bear in mind, however, this study has demonstrated the possibility of limited control of an object where the number of DOFs is larger than that of independent drives.

In the context of the control process, the platform's motion is treated as superposition of the hoisting motion caused by the non-stretching rope section being wound onto drums with the variant, programmable rpm and of the relative movement of the platform's side edges with respect to the ropes' end sections. Nonzero average values of the signals  $\Delta f_1$  and  $\Delta f_2$  are associated with the necessity for static correction of asymmetry of the motors' loading. Intensive fluctuations of deviations of instantaneous values of feedback signals shown in Fig. 9 lead to reduction of horizontal and angular vibrations of the platform.

Satisfying the requirements associated with vibration reduction of a modified platform structure will allow the vector methods to be implemented in the drive control [4, 8].

## References

- [1] Chwastek, S., *Stabilizacja i poziomowanie linowych platform podwieszanych metodami wektorowego i skalarowego sterowania przemiennikami częstotliwości*, Problemy Maszyn Roboczych, Z. 34, pp. 5–15, 2009.
- [2] Chwastek, S., *Optimal stabilisation of platforms suspended by ropes using the frequency converter control method*, Transport Problems, International Scientific Journal, Is. 4, pp. 61-68, Gliwice 2011.
- [3] Chwastek, S., *Pozycjonowanie i stabilizacja położenia platformy podwieszanej z uwzględnieniem drgań poziomych wywołanych przemieszczaniem się osób*, Przegląd Mechaniczny, 1'12, pp. 35–39.
- [4] Dembowski, A., Chudzik, P., Lewandowski, D., *Napęd asynchroniczny ze sterowaniem momentu*, Napędy i sterowanie, Miesięcznik naukowo-techniczny, Nr 4 (120), pp. 137–146, 2009.
- [5] Engel, Z., Kowal, J., *Sterowanie procesami wibroakustycznymi*, Wydawnictwa AGH, 1995.
- [6] Heimann, B., Gerth, W., Popp, K., *Mechatronika*, PWN, Warszawa 2001.
- [7] PN – 90/B – 03200, *Konstrukcje stalowe*, Obliczenia statyczne i projektowanie.
- [8] Sieklucki, G., *Automatyka napędu*, Wydawnictwa AGH, Kraków 2009.
- [9] Tunia, H., Kaźmierkowski, M., *Automatyka napędu przekształtnikowego*, WKŁ, Warszawa 1987.